



DL12SP



DL12DP

DL12 series Counter top sheeter

The Doyon DL12 series dough sheeter is an efficient one (DL12SP) or two stage (DL12DP) machine featuring a front infeed and discharge. Ergonomic design makes it easy and simple to operate.

Sheeting is made easy with this compact, counter top design that is simple to use. Back strain is reduced since rolling pin work is minimized or eliminated. Save time and effort

Sheet dough up to 12" (305 mm) in diameter to a uniformed thickness in seconds. One operator can make up to 250 pieces per hour in just two easy steps.

The Quick Change Index System quickly changes the gap between the dough rollers. Sheet all types of dough including cinnamon rolls, doughnuts, perogies, danish and puff pastry up to 12" (305 mm).

DL12SP & DL12DP

"Superior *quality* product
at an *affordable* price !"

COUNTERTOP CRUST SHEETER

Standard Features

- Sanitary plastic precision ground rollers
- Synthetic rollers eliminate dough build up
- Compact design, ideal for use in limited space
- Sanitary, heavy duty, all stainless steel welded construction
- Stainless steel spring loaded scrapers easily removable for cleaning
- Simple handle adjustments for exact uniform dough thickness
- Ergonomic design for easy operation
- Convenient side or front operation
- Maintenance free drive mechanism
- Drive mechanism isolated from roller area
- Sealed ball bearings, permanently lubricated
- Will sheet up to 12" (305 mm) diameter
- One operator can make up to 250 pieces per hour
- Safe and easy operation
- ETL & ETL Sanitation listed
- One year parts and labor limited warranty

OPTIONAL

- Foot switch control for DL12DP
- 220V - 1PH - 50 Hz
- Model conform to requirements of RSST, conforms to the following norms and requirements:
 - EN 954-1 article 6.2.1
 - CSA Z432-04, articles 6.2.1.9.2, 6.2.1.9.3, 6.2.1.9.4, 6.2.3.2, 7.17, 10.2
 - RSST articles 172 à 175, 182, 184, 187, 189, 190, 192

OVERALL DIMENSIONS

DL12SP

17" W X 10 5/8" D X 12 1/2" H
(432 mm X 270 mm X 318 mm)

Rollers: 2" X 12" (51 mm X 308 mm)

DL12DP

17" W X 10 5/8" D X 25 1/4" H
(432 mm X 270 mm X 641 mm)

Bottom Rollers: 2" X 12" (51 mm X 308 mm)

ELECTRICAL SYSTEM

120V - 1 PH - 370 Watts - 60 Hz

Heavy duty, maintenance free 1/2 HP motor

CAPACITY

Sheets from 1oz to 10.5 oz (30g to 300g) of dough
Maximum rollers gap : 13/64" (5 mm)
Up to 250 dough pieces per hour

FINISH

Stainless steel

SHIPPING WEIGHT

60 lb (27 kg) approximately

Specifications and design subject to change without notice.

DL12SP

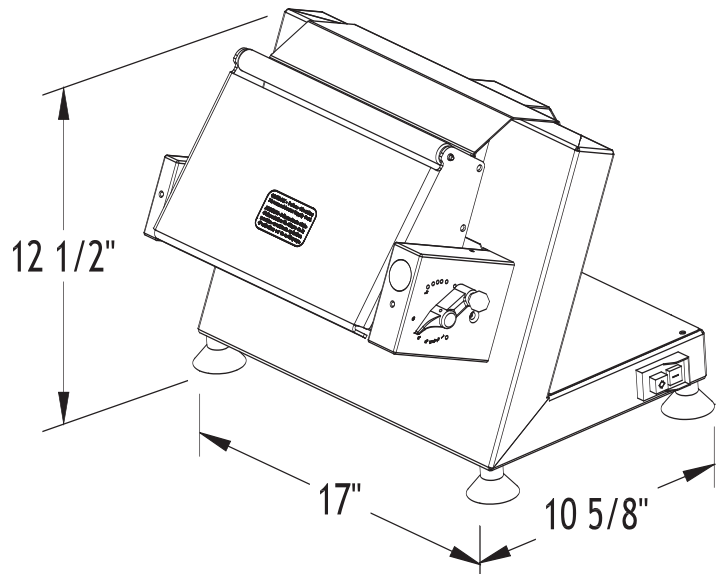

DL12DP

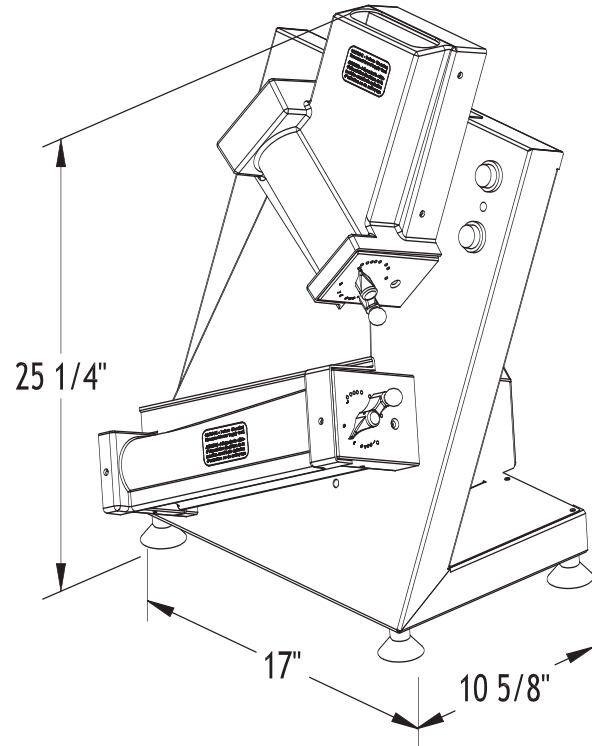

Foot switch pedal for DL12DP



Conforms to ANSI/UL std. 763 Conforms to Certified to CSA C22.2 no.195 ANSI/NSF8

Your local distributor:

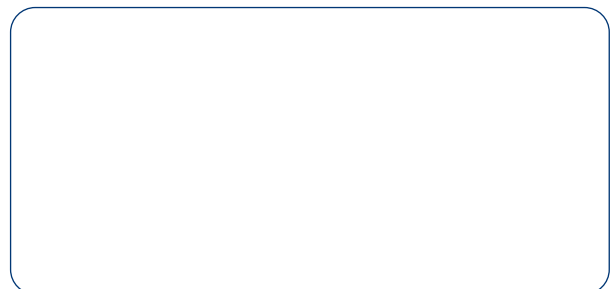

1255, rue Principale
Linière, Beauce, Québec, Canada G0M 1J0

Telephone : (418) 685-3431 Fax: (418) 685-3948
Canada : (800) 463-1636 U.S.: (800) 463-4273
E-Mail : doyon@doyon.qc.ca Internet: http://www.doyon.qc.ca